

WEATHER

THE STORM



Vaughan
Unmatched Reliability



IF YOU ARE MANAGING MUNICIPAL FACILITIES IN STORM-PRONE REGIONS, VAUGHAN HAS A CLEAR SOLUTION.

INTRODUCING THE CHOPPER PUMP STORM™

This fully enclosed pump is a stand-alone unit. It's the skid-mounted, emergency backup solution you've been waiting for.

INTRODUCING THE CHOPPER PUMP STORM™

- 100% Lift Station Redundancy
- No need to activate Switch Gear during an emergency
- Powered by either Diesel (Interim Tier 4) or Natural Gas/LPG/Propane
- Eliminates pump issues caused by mechanical and electrical failures
- Available with Automatic Control System with remote operation and monitoring
- Capable of auto throttling engine RPM in response to changing Pressure/Level/Flow Transducer signals with backup Float switch operation
- Skid Mount, Sound Attenuated
- Strong Pump & Engine Shell: A 14-gauge galvanized steel outer shell
- The Enclosure provides easy access to the working parts of the engine, pump and controls without having to remove the access panels for inspection, cleaning and servicing of the pump equipment
- All Access Panels are lockable
- Dry Prime Vacuum Pump Priming System
- Interior & Exterior Work Lights
- SCADA Interface via MODBUS Communication
 - Ethernet Plug – RJ45 connector
 - Wired for RS485 (MODBUS RTU or ASCII)
- Shore Power and/or Solargizer Battery Maintainer

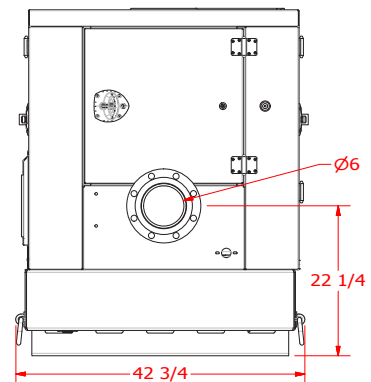
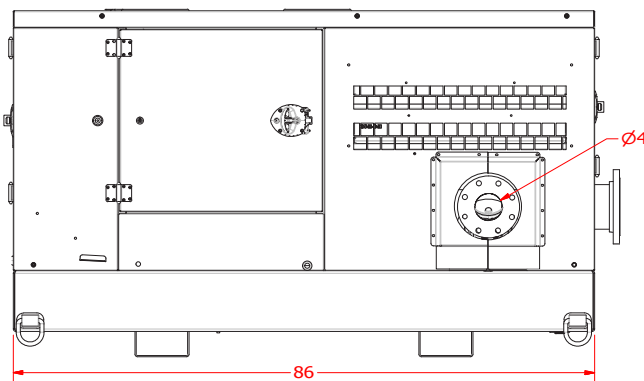

**BE PREPARED FOR THE NEXT STORM, POWER OUTAGE, OR EMERGENCY SHUTDOWN.
CONTACT VAUGHAN AT CHOPPERPUMPS.COM TO UPGRADE YOUR EMERGENCY KIT.**